

35207, 35208

scale 1/35

產品編號: 35207, 35208

1:35 比例

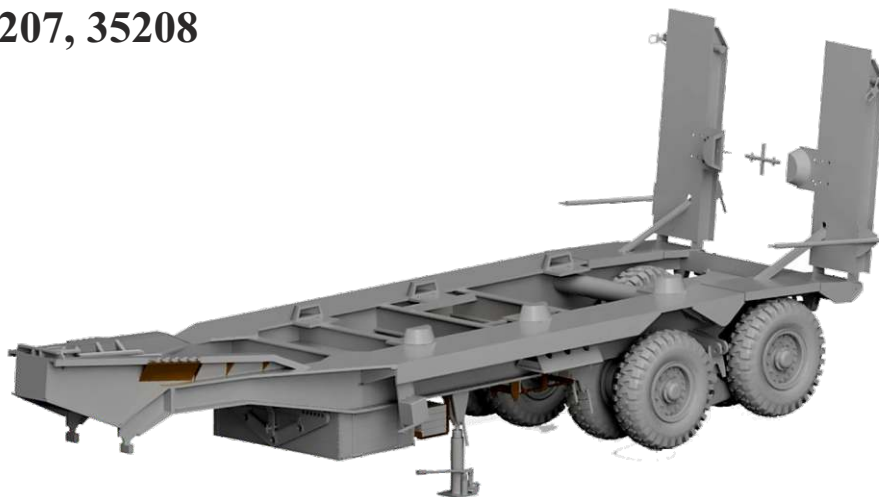

1/35 British Scammell Pioneer 30t Trailer TRCU30 Late Goose-Neck

Go through this assembly guide and understand it before you start kit assembly

Use usual plastic kit's cements and tools (not included in the kit)

Follow painting guide supplied, use only hobby paints

Work carefully with photo etched parts if included, use C/A glues to assemble them

請您在組裝此產品前仔細閱讀組裝指南;

請使用通用塑膠模型黏合劑和工具(本產品不附帶);

本產品所以提供的噴塗指南只適用本於模型;

如果本產品含有蝕刻套件,請小心仔細處理,請使用C/A膠水組裝;

組み立て前にこの組み立てガイドをご覧ください。

プラスチックキット専用接着剤と専用工具をご使用ください。(ともにキットには含まれていません)

塗装ガイドに従ってください。専用塗料をご使用ください。

エッチングパーツの組み立ては細かいパーツのため注意が必要です。また接着には瞬間接着剤を使用してください。



cut/remove

切下 / 移除

切断/切り離し



drill hole

鑽孔

ドリル穴



no glue

不適用膠水

接着しない



bend

折彎

折り曲げ



cyanoacrylate glue

氰基丙烯酸酯膠水

瞬間接着剤



string or wire

細繩或者金屬絲線

糸または金属線



rope

繩

ひも



paint area during assembly
(ref. to AMMO colors)

裝配過程中的噴漆區域推薦
(請參考AMMO顏色)

組み立て時の塗装部分
(コード例: AMMOカラー)



PE - press rivets (lines)
from the etched off side

蝕刻片 -
請从蚀刻掉的一侧压铆钉 (线)

ラインやリベット部分を未エッチング面から圧を与える

The Scammell Pioneer was a British 6x4 tractor used in the Second World War as an artillery tractor, recovery vehicle and tank transporter. Pioneers purchased by the British Army were equipped with a 102 bhp Gardner 6 cylinder diesel engine. The production of the tank transporter begun in 1937, although the prototype had been built already in 1932. The tractor was equipped with a longer chassis and extended cab to accommodate the tank crew as passengers, and larger rear wheels than the Artillery tractor and Recovery vehicle variants. Initial 20 ton Pioneer TRCU20 trailer, then 30 ton Pioneer TRMU30/TRCU30 tractor and trailer combinations were delivered, in both cases with the trailer fixed to the tractor. Hinged ramps were used to get the tank onto the trailer, which could be pulled on with the tractor unit's winch (TRCU30 standard and late "Goose Neck" trailers), but the initial 20 ton trailer used system of jacks and removable rear bogies to load or unload tanks. Pioneer tractor/trailer combinations remained in production throughout the war, 459 units produced in total. Our special thanks to Henri Van Meel for his help with references.

スカメル・パイオニアは英国製 6 輪 4 輪駆動トラクターで第二次大戦で砲兵牽引車、車両回収車そして戦車輸送車として使用されました。

102馬力6気筒ディーゼルエンジンのタイプを陸軍が購入しました。

1932年にすでに試作が開発され、1937年に戦車運搬トレーラーは生産が開始されました。

そのトラクタータイプはシャーシが長いロングボディーで同乗する戦車兵用にキャビンは延長されました。

そして砲兵牽引や回収車タイプより大きな後部タイヤを装着されました。初期型の20トン・パイオニアTRCU20、後期型30トン・パイオニア

TRCU30各トレーラーとそのトラクターTRMU30は各トレーラーとの組み合わせで供給されました。トレーラーとトラクターの結合は通常固定されていました。

戦車をトレーラーに上車するためのヒンジ可動のランプ（傾斜台）はトラクターに装着のウインチで引上げられました。

（ウインチはTRCU30型標準タイプ。アームタイプトレーラーに到着されていたもの）しかし初期型の20トントレーラーは戦車の昇降車時ジャッキを使い、

後部車台を外す仕様でした。パイオニア戦車運搬車ユニットは第二次大戦を通じて生産を継続され459両が生産されました。

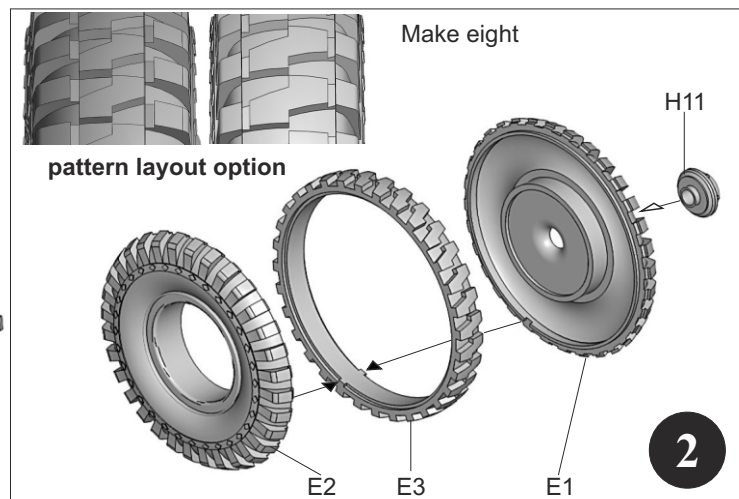
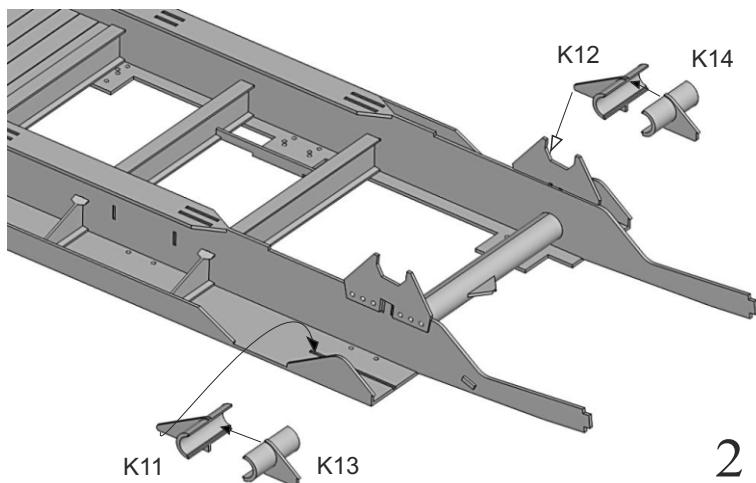
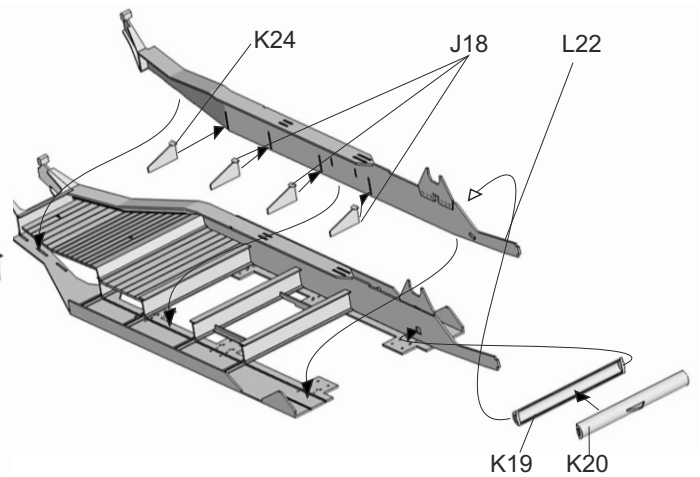
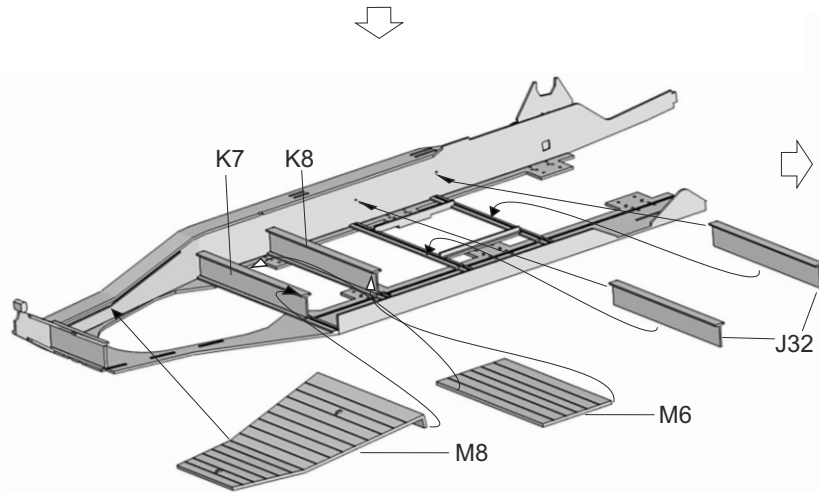
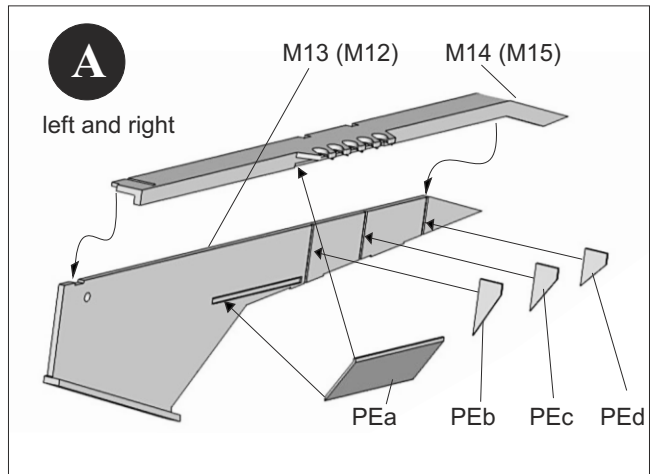
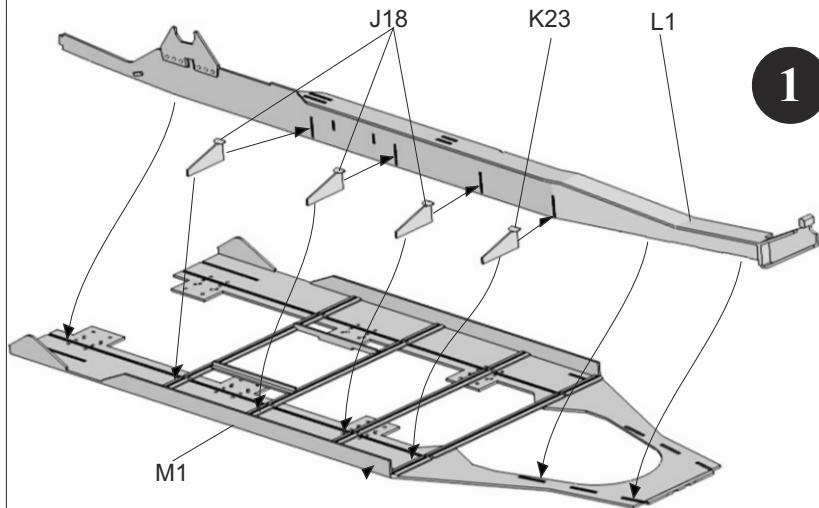

1

2

2

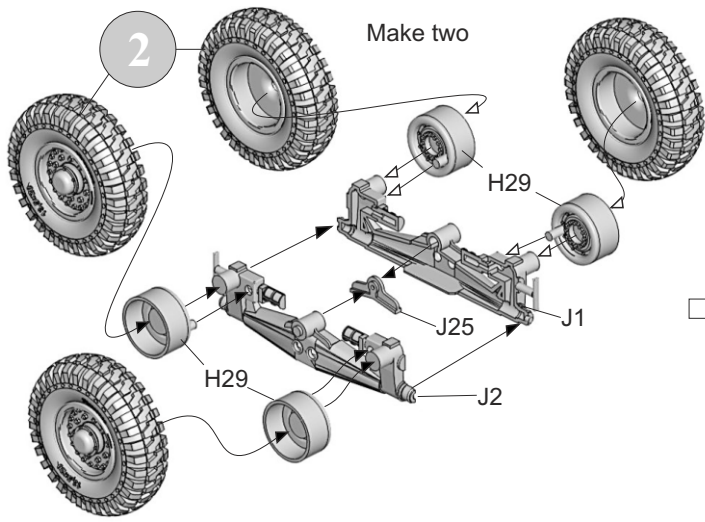

3

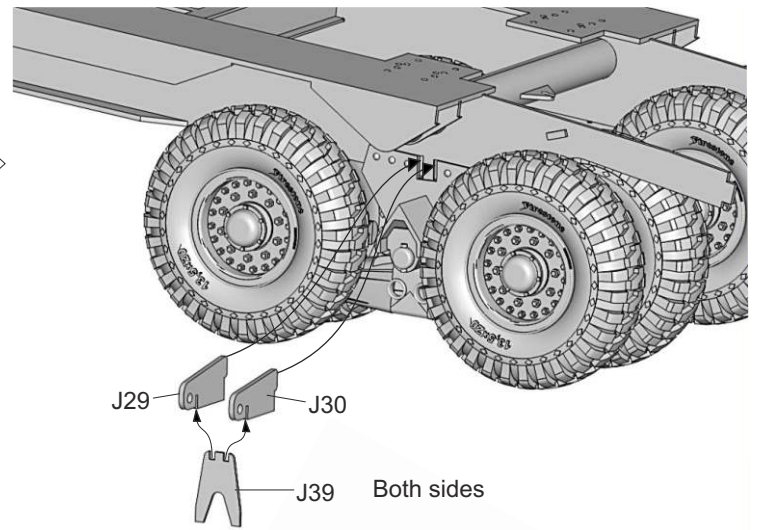
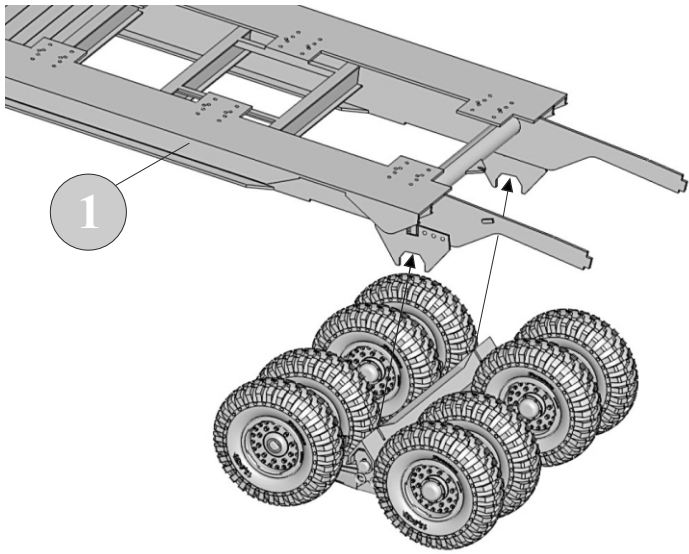
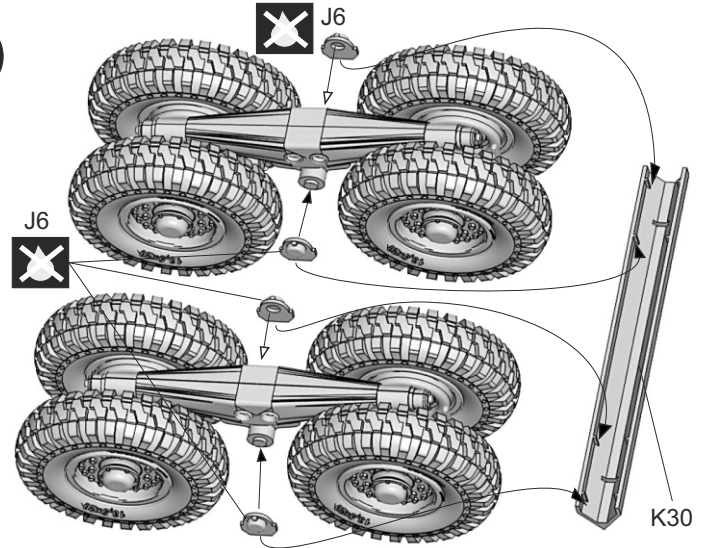

4

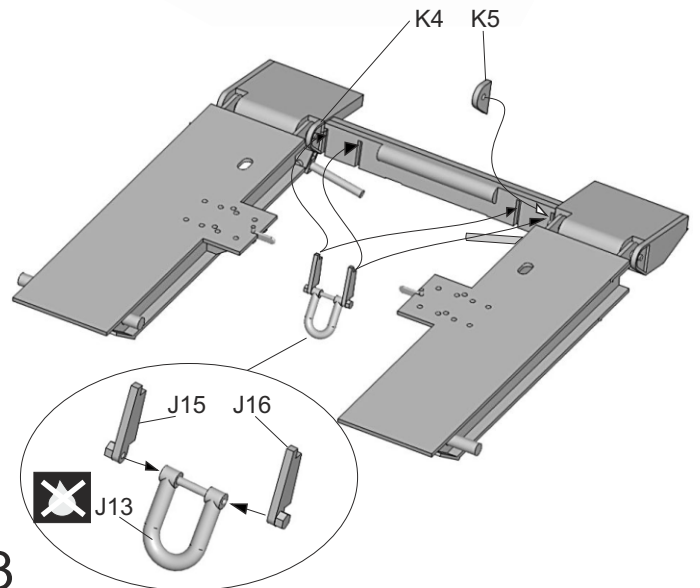
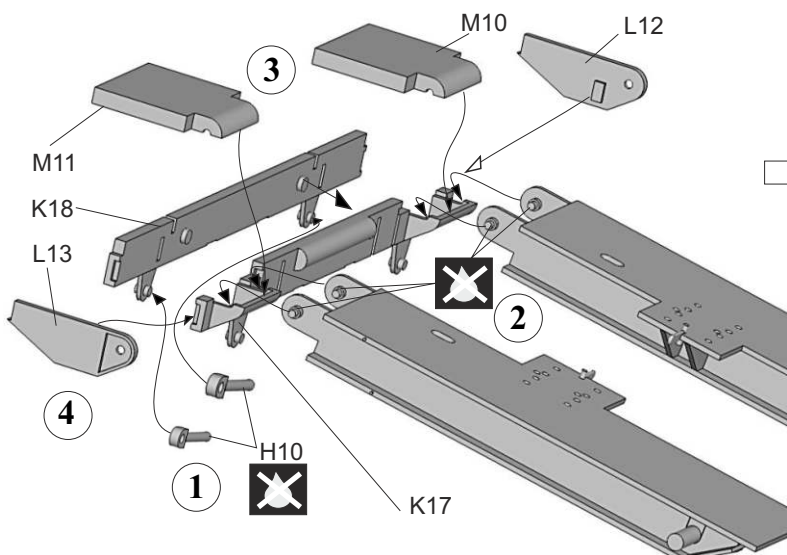
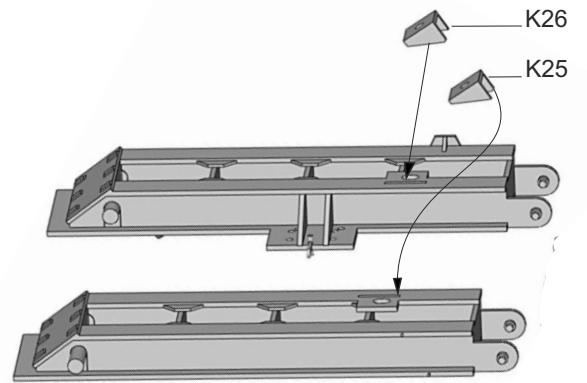
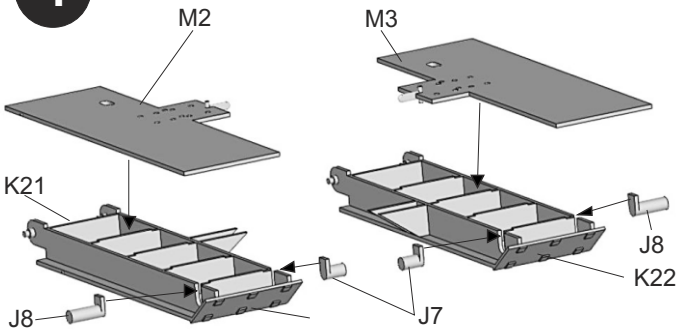

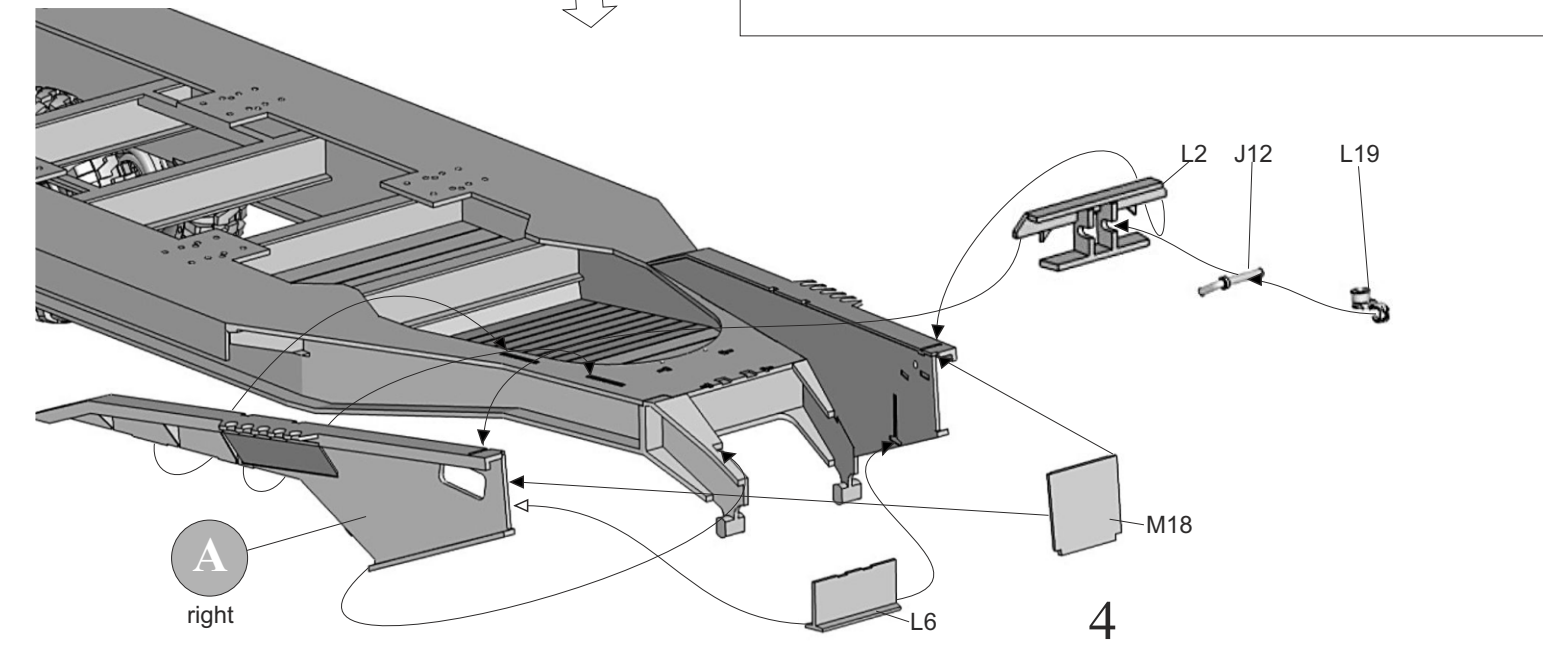
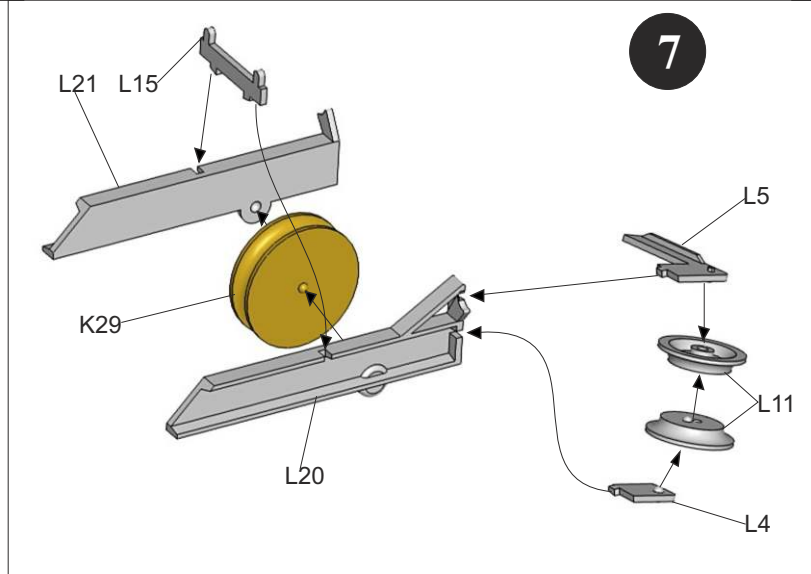
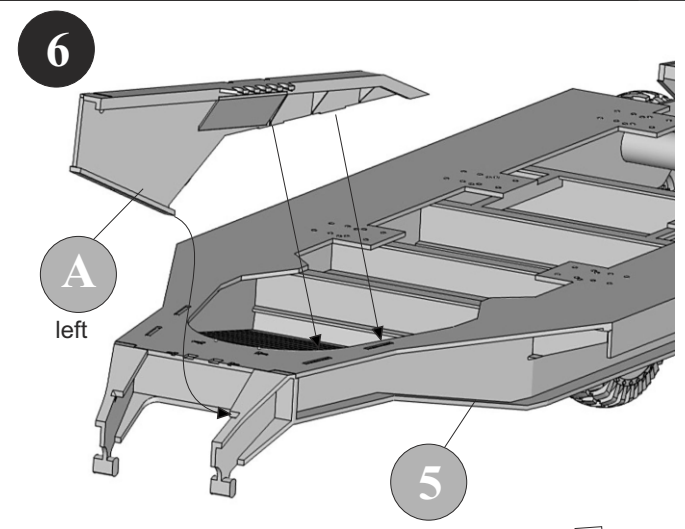
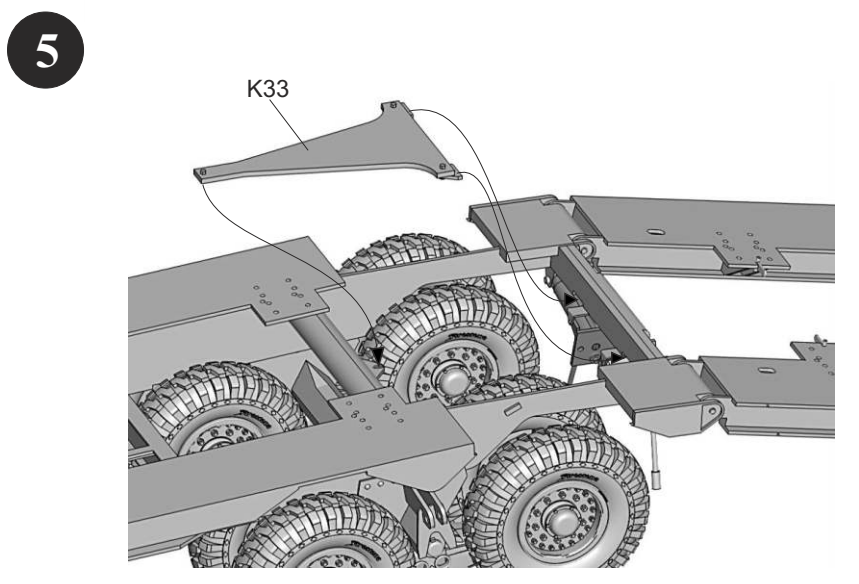
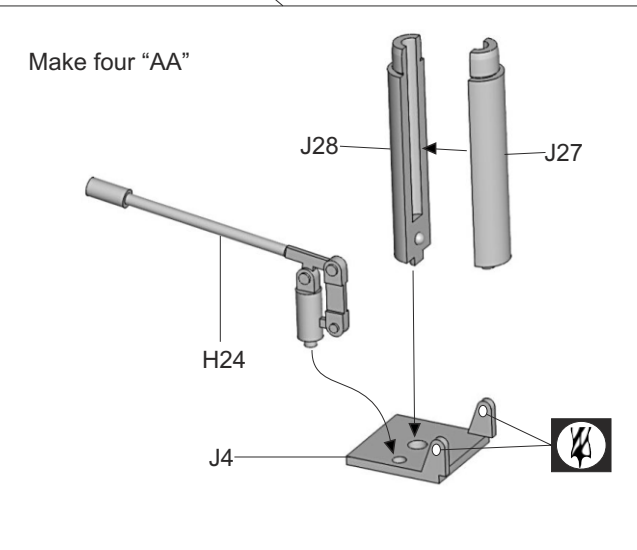
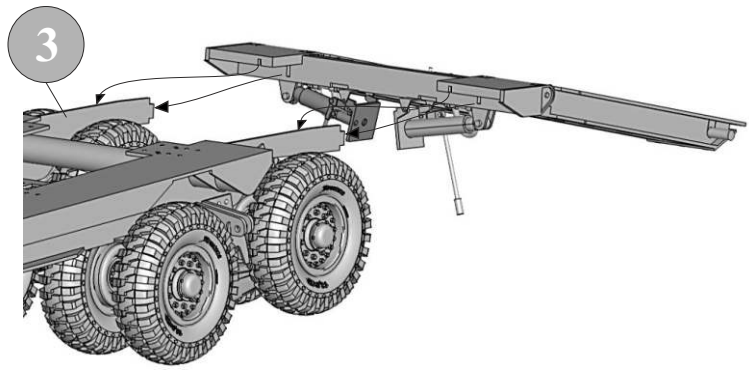
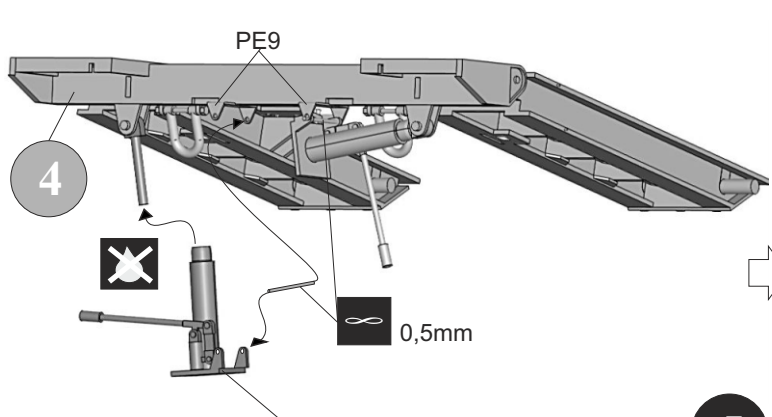

8

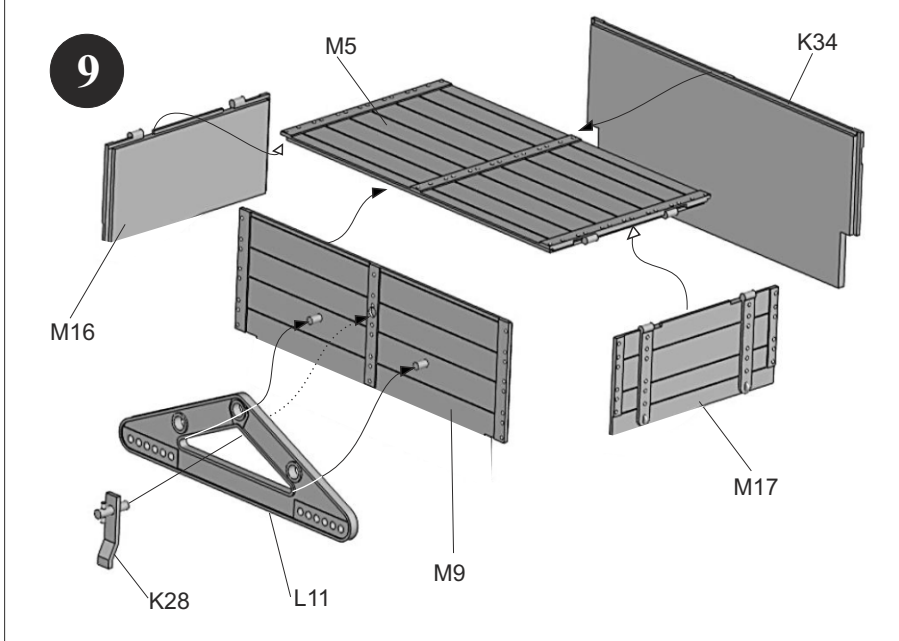
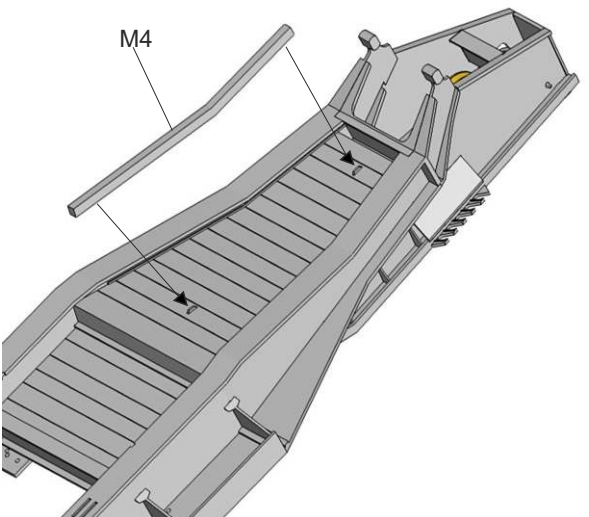
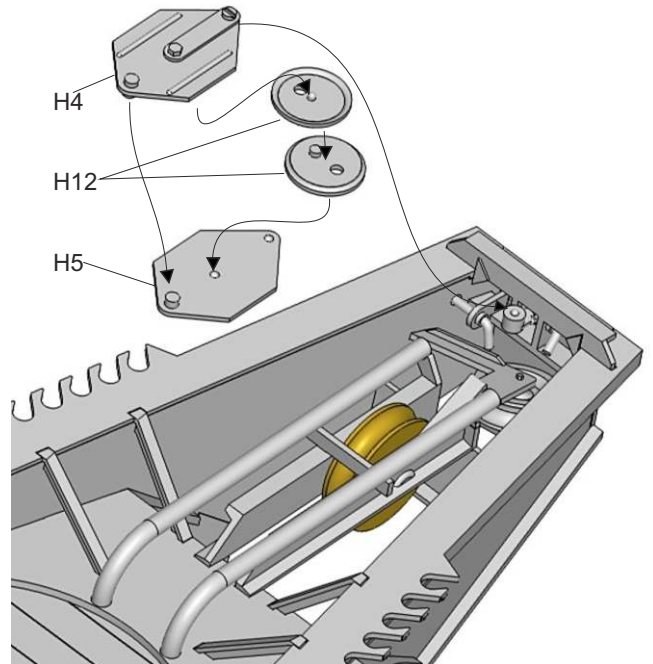
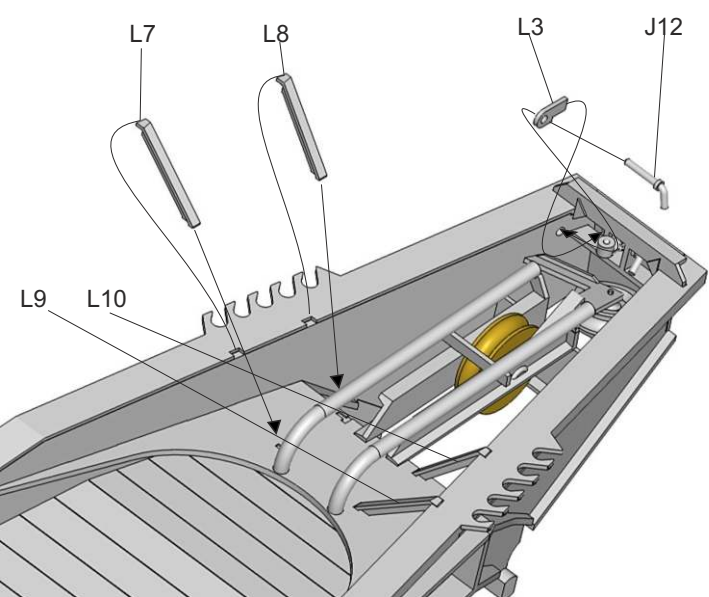
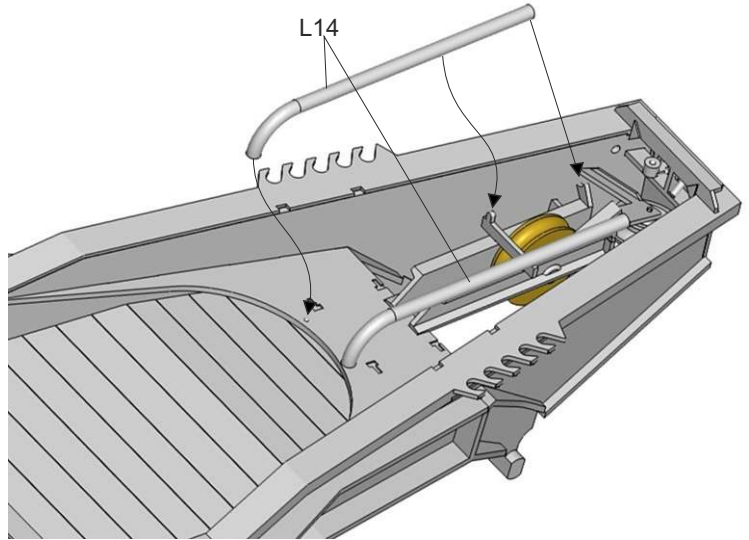
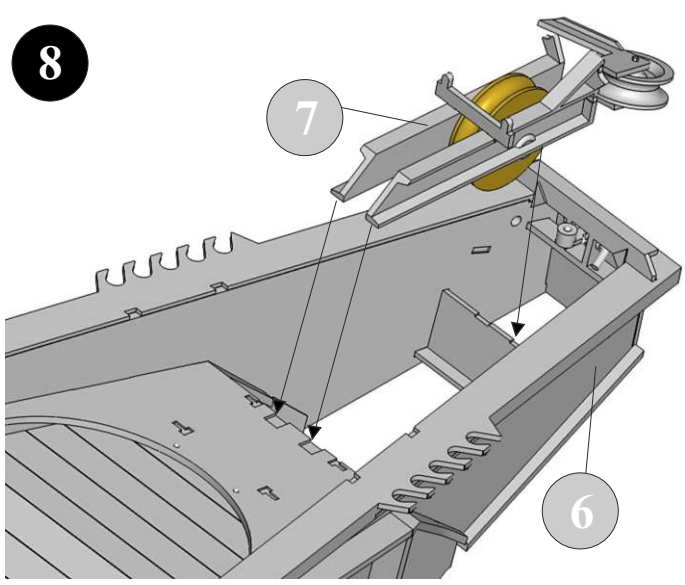

5

9

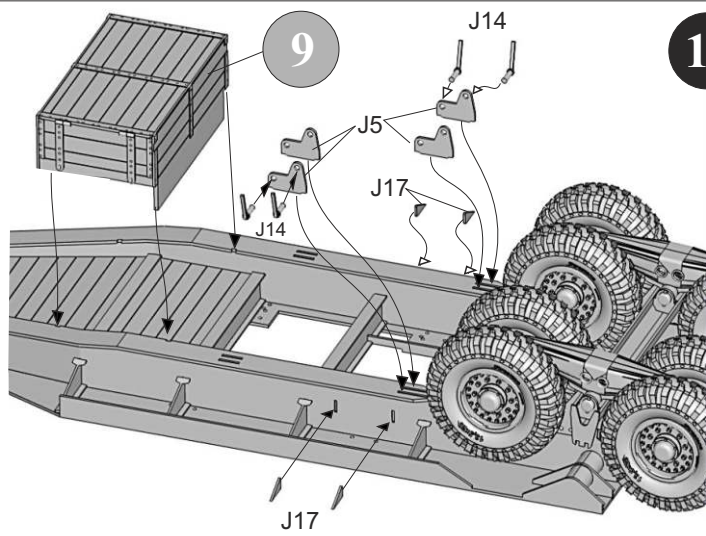

10

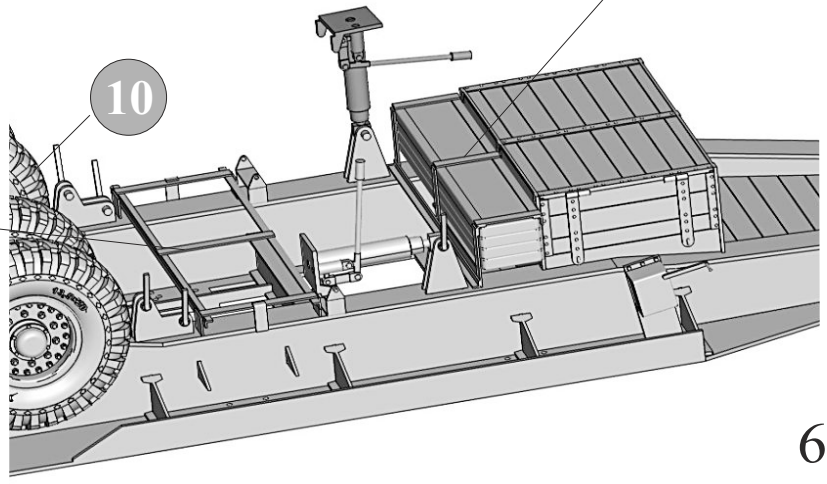
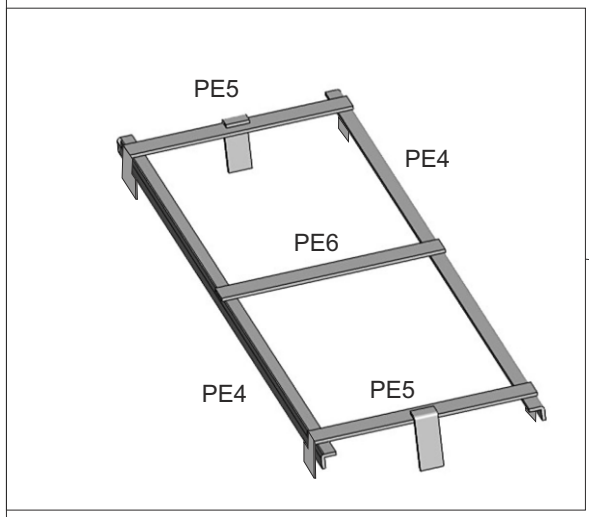
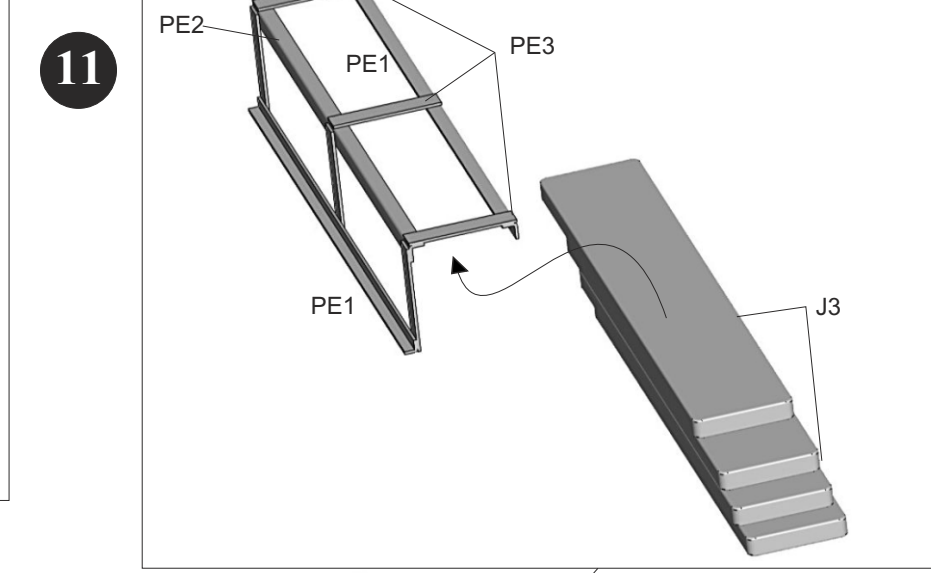
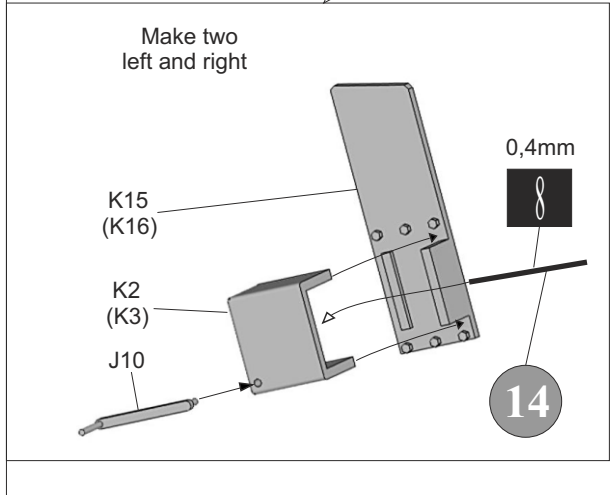
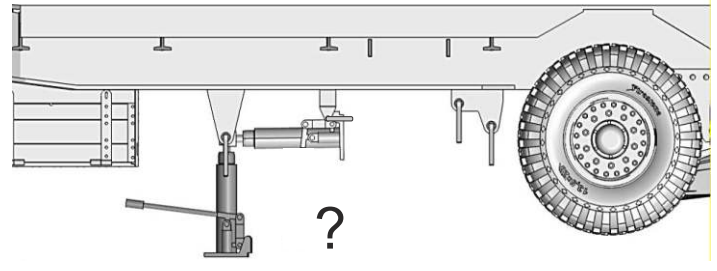
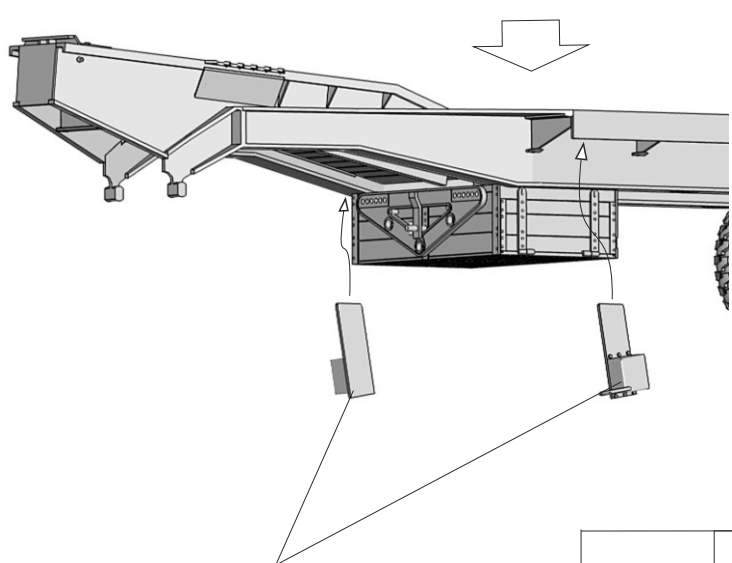
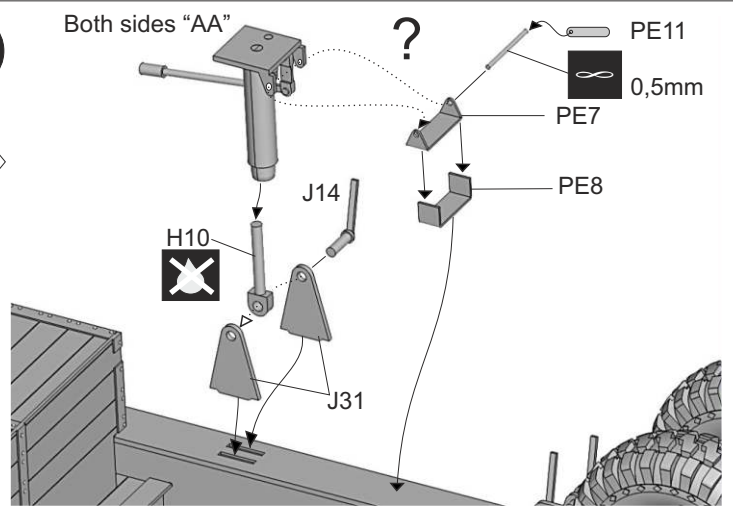

12

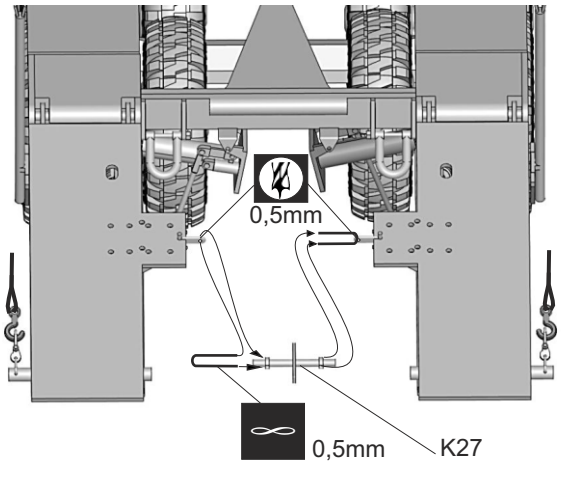
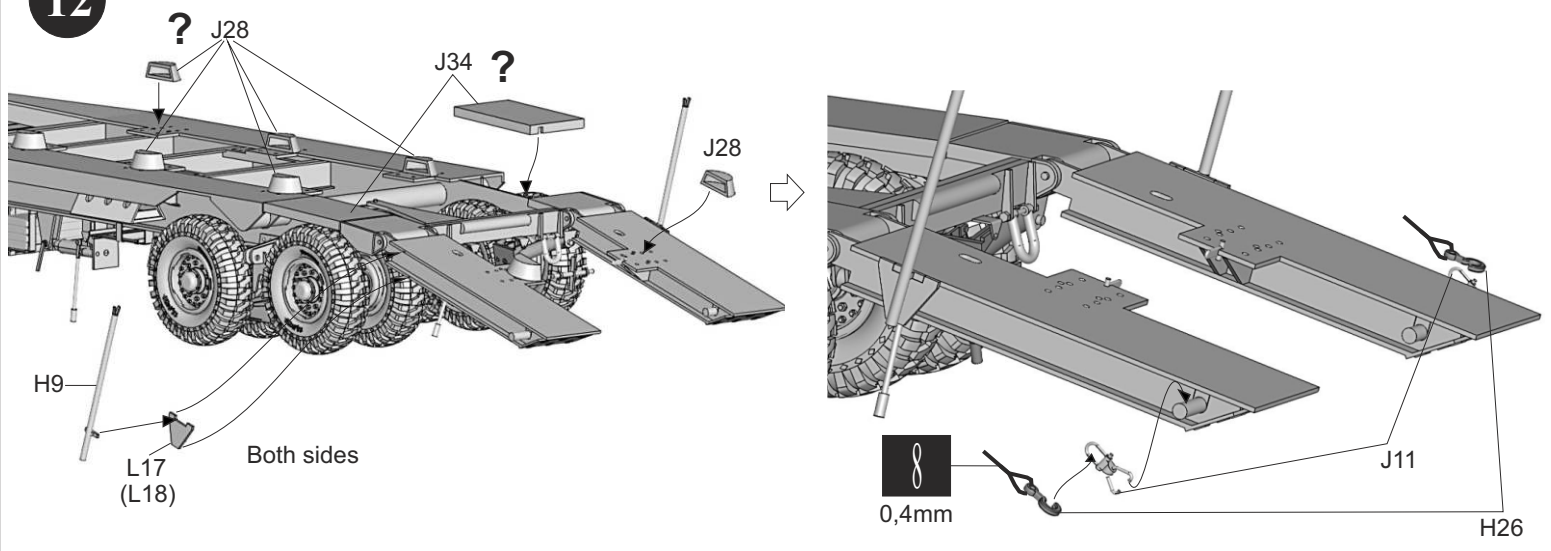

13

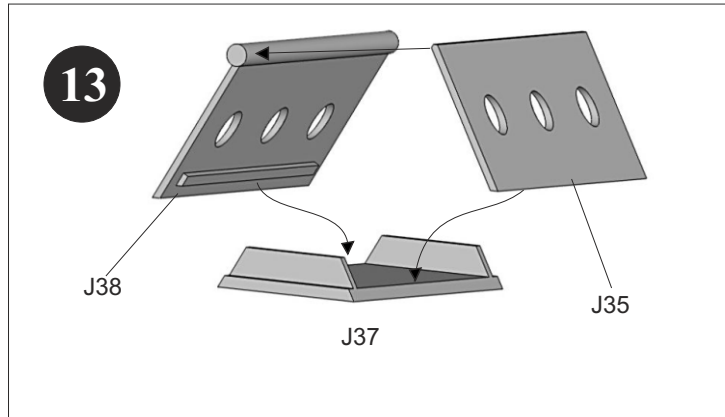

Option ramps down

14

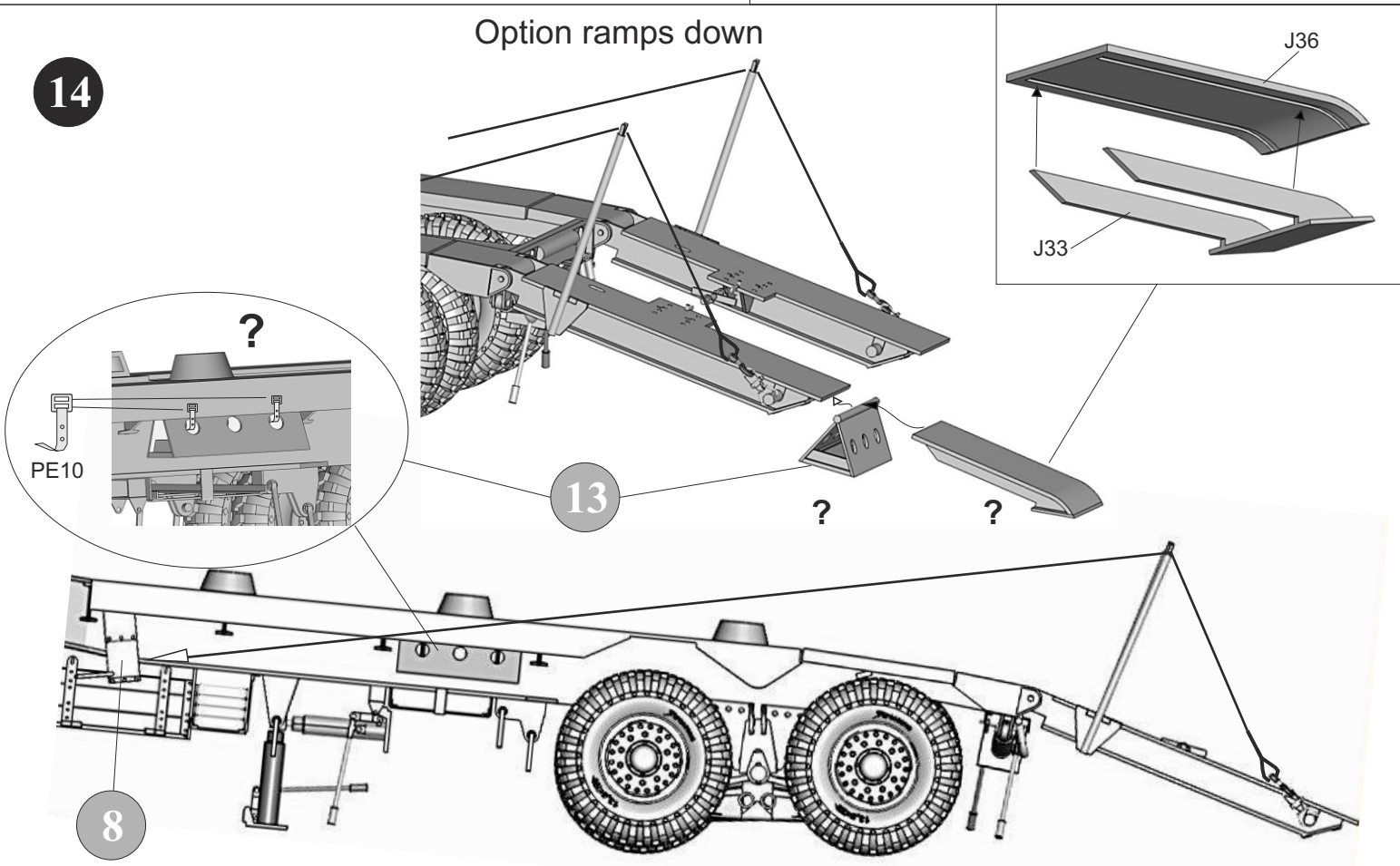

tension rope diagram

15

Option ramps up

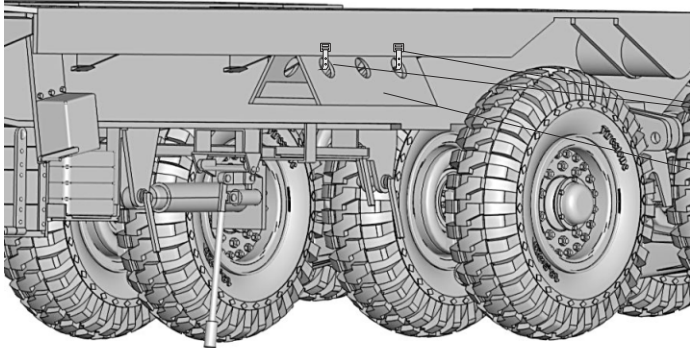
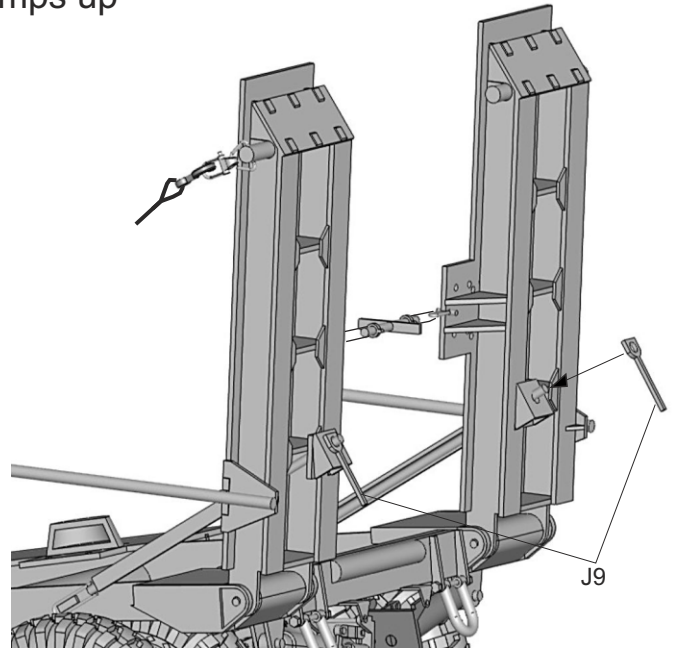
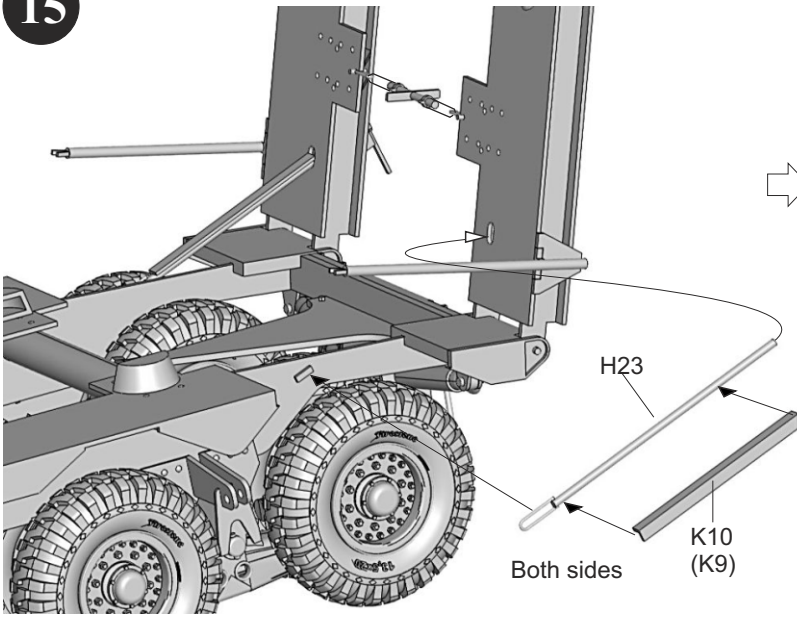

tension rope diagram

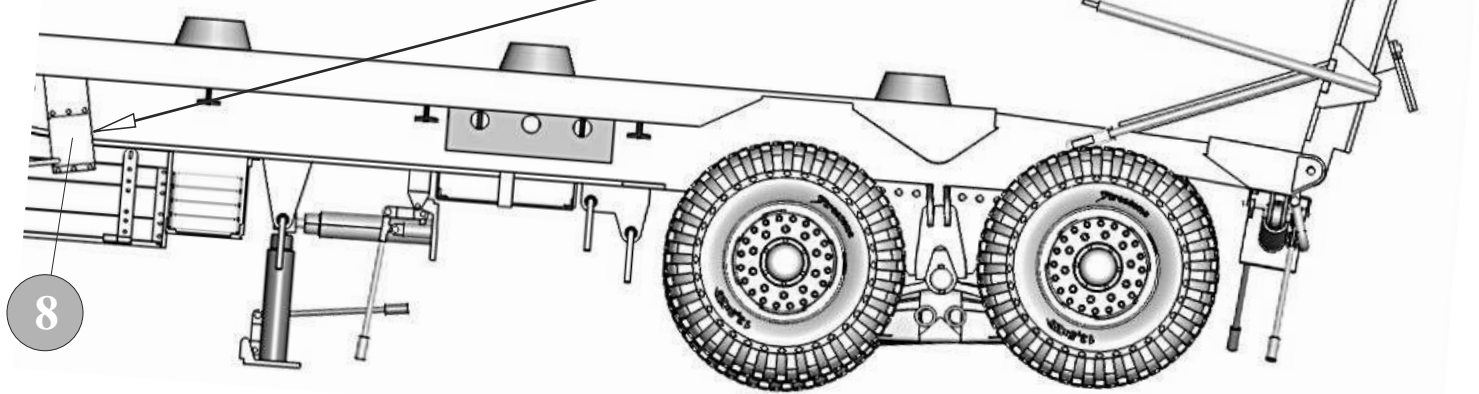

14

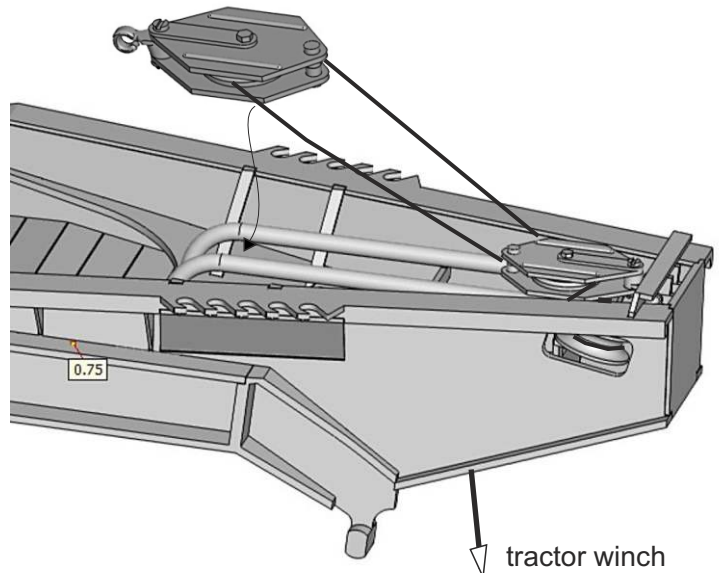
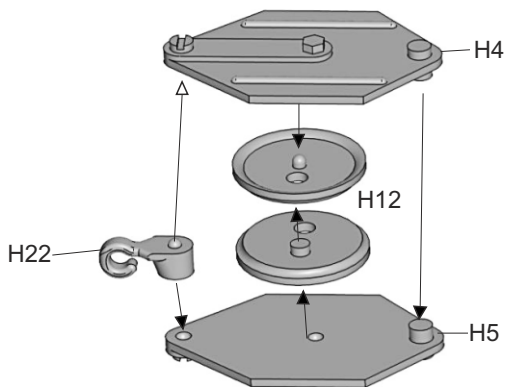

8

Binding examples

J24

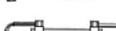

J19 and J20
screw pullers
H21 and J24
binding accessories

